

NITROGEN GENERATOR

N-GEN (PSA nitrogen generator)

DESCRIPTION

The N-GEN nitrogen generators extract the available nitrogen in the ambient air from the other gases by applying the Pressure Swing Adsorption (PSA) technology. During the PSA process compressed, cleaned ambient air is led to a molecular sieve bed, which allows the nitrogen to pass through as a product gas, but adsorbs other gases. The sieve releases the adsorbed gases to the atmosphere, when the outlet valve is closed and the bed pressure returns to ambient pressure. Subsequently the bed will be purged with nitrogen before fresh compressed air will enter for a new production cycle. In order to guarantee a constant product flow N GEN nitrogen generators use two molecular sieve beds, which alternatively switch between the adsorption and the regeneration phase.



APPLICATIONS

- Blanketing of Chemicals and Pharmaceuticals
- Gas Assisted Injection Moulding (GAIM)
- Heat Treatment of Ferrous & Non-Ferrous Metals
- Inerting of Flammable Liquids
- Laser Cutting
- Prevention of Dust Explosions
- Re-flow and Wave Soldering of PCBs
- UV-Curing of Coatings
- Food Processing

TECHNICAL SPECIFICATIONS

Operating pressure	from 6 to max 10 barg
Inlet temperature range (feed air)	10°C up to 55 °C
Dew point (at ambient pressure)	<-45°C
Voltage, Frequency	110–230 V / 50–60 Hz
Power consumption	<60 W
Sound level	up to 90 dB(A)
Protection class (controller)	IP 54
Compressed air quality (inlet)	Class 1.4.1 acc. to ISO 8573-1 (0,1µm; 3°C; <0,01mg/m3/h)
Filters (inlet + outlet)	Included

MATERIALS

Columns, construction, support	Carbon Steel
Column inner protection	/
Column and construction protection	Epoxy powder painted
Valves	Brass, Stainless steel
Fitting, screws, plugs	INOX, brass, steel (zinc coated)
Outside protection	Epoxy powder painted
Adsorbent	Carbon molecular sieve (CMS) and inert material

SIZES

Model	Connection [inch]		Length A [mm]	Width B [mm]	Height C [mm]	Mass [kg]	Volume* [l]
	IN	OUT					
N-GEN 03	½"	½"	1097	550	1665	171	14
N-GEN 05	½"	½"	1126	550	1768	191	23
N-GEN 10	½"	½"	1100	550	1674	230	36
N-GEN 15	½"	½"	1102	550	1804	310	63
N-GEN 20	1"	½"	1152	550	1968	345	72
N-GEN 25	1"	½"	1282	760	2094	585	105
N-GEN 35	1"	½"	1398	760	2103	720	176
N-GEN 50	1"	½"	1450	760	2140	870	225
N-GEN 65	1"	½"	1650	860	2211	955	280
N-GEN 80	1"	1"	1749	860	2361	1215	305
N-GEN 100	2"	1"	2003	1010	2273	1660	480
N-GEN 150	2"	1"	2107	1180	2387	2540	750
N-GEN 200	2"	2"	2434	1325	2404	3035	970
N-GEN 250	2"	2"	2603	1425	2510	4100	1210
N-GEN 300	2"	2"	2815	1630	2629	4998	1540
N-GEN 400	DN65 FLG	DN40 FLG	3100	1690	2889	6850	2140

* per column

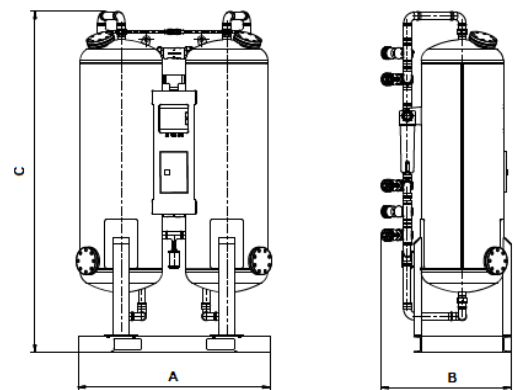

PERFORMANCE at inlet temperature 30 °C

Model	INLET PRESSURE [barg]	DISCHARGE PRESSURE [barg]	RESIDUAL OXYGEN [vol. %]						
			3	2	1	0,5	0,1	0,01	0,001
			TOTAL INERT GAS PURITY [vol. %]						
			97	98	99	99,5	99,9	99,99	99,999
N-GEN 03; N2 flow [m3/h]	7,5	6,3	5,84	5,58	5,13	3,63	2,74	1,61	0,90
Feed air consumption [m3/h]			12,3	12,0	11,0	10,2	10,2	8,1	5,2
N-GEN 05; N2 flow [m3/h]	7,5	6,3	9,34	8,91	8,21	5,80	4,39	2,58	1,44
Feed air consumption [m3/h]			19,6	19,2	17,6	16,2	16,2	12,9	8,3
N-GEN 10; N2 flow [m3/h]	7,5	6,3	14,4	13,7	12,6	8,9	6,8	4,0	2,2
Feed air consumption [m3/h]			30,2	29,5	27,2	25,0	25,0	19,8	12,8
N-GEN 15; N2 flow [m3/h]	7,5	6,3	23,8	22,7	20,9	14,8	11,2	6,6	3,7
Feed air consumption [m3/h]			49,9	48,8	44,9	41,3	41,3	32,8	21,2
N-GEN 20; N2 flow [m3/h]	7,5	6,3	28,6	27,3	25,1	17,7	13,4	7,9	4,4
Feed air consumption [m3/h]			60,0	58,6	54,0	49,7	49,7	39,4	25,4
N-GEN 25; N2 flow [m3/h]	7,5	6,3	42,7	40,7	37,5	26,5	20,0	11,8	6,6
Feed air consumption [m3/h]			89,6	87,6	80,6	74,2	74,2	58,9	38,0
N-GEN 35; N2 flow [m3/h]	7,5	6,3	67,7	64,6	59,5	42,0	31,8	18,7	10,5

Feed air consumption [m3/h]			142,1	138,8	127,8	117,7	117,6	93,3	60,2
N-GEN 50; N2 flow [m3/h]	7,5	6,3	86,9	82,9	76,3	54,0	40,8	24,0	13,4
Feed air consumption [m3/h]			182,4	178,3	164,1	151,1	151,0	119,8	77,3
N-GEN 65; N2 flow [m3/h]	7,5	6,3	106,6	101,7	93,6	66,2	50,1	29,4	16,5
Feed air consumption [m3/h]			223,8	218,7	201,3	185,4	185,2	146,9	94,9
N-GEN 80; N2 flow [m3/h]	7,5	6,3	118,8	113,4	104,4	73,8	55,8	32,8	18,4
Feed air consumption [m3/h]			249,5	243,8	224,5	206,6	206,5	163,8	105,8
N-GEN 100; N2 flow [m3/h]	7,5	6,3	178,2	170,1	156,6	110,7	83,7	49,2	27,5
Feed air consumption [m3/h]			374,3	365,8	336,8	310,0	309,8	245,8	158,7
N-GEN 150; N2 flow [m3/h]	7,5	6,3	273,90	261,45	240,70	170,15	128,65	75,53	42,33
Feed air consumption [m3/h]			575,2	562,1	517,5	476,4	476,0	377,7	243,8
N-GEN 200; N2 [flow m3/h]	7,5	6,3	344,3	328,6	302,5	213,9	161,7	94,9	53,2
Feed air consumption [m3/h]			723,0	706,5	650,5	598,8	598,3	474,7	306,5
N-GEN 250; N2 [flow m3/h]	7,5	6,3	419,2	400,2	368,4	260,4	196,9	115,6	64,8
Feed air consumption [m3/h]			880,4	860,4	792,1	729,2	728,6	578,0	373,2
N-GEN 300; N2 [flow m3/h]	7,5	6,3	534,6	510,3	469,8	332,1	251,1	147,4	82,6
Feed air consumption [m3/h]			1122,7	1097,1	1010,1	929,9	929,1	737,1	475,9
N-GEN 400; N2 [flow m3/h]	7,5	6,3	727,8	694,7	639,6	452,1	341,8	200,7	112,5
Feed air consumption [m3/h]			1528,4	1493,6	1375,1	1265,9	1264,8	1003,5	647,9

Refers to 1 bar(a) and 20 °C at 7,5 bar operating pressure. Inlet temperature 30 °C.

For nitrogen flow capacity at other conditions and purity please contact manufacturer.

Performance +/- 5%.

STANDARD EQUIPMENT

- Set of External Feed Air Filters
- Adsorber Vessels in Carbon Steel
- Long life Pneumatic and Solenoid Valves
- Internal Piping & Fittings Zinc Plated Carbon Steel
- Product Pressure Transmitters
- Nitrogen and Air Flow Regulation
- Pressure Regulator
- Control System with SIEMENS PLC
- WebControl

OPTIONAL EQUIPMENT

- Oxygen Analyser
- Electronic Product Flow Meter
- Feed Air / Product Moisture Analyser
- Feed Air / Product Temperature Transmitters
- Nitrogen Sterile Filters
- Nitrogen Booster
- Nitrogen Cylinder Filling System
- Touch Screen Interface

INFORMATION IN THIS DOCUMENT IS SUBJECT TO CHANGE WITHOUT NOTICE

 <p>BUREAU VERITAS</p>	<p>Our quality management system is certified by BUREAU VERITAS in conformity with ISO 9001:2015 Reg. number: 200285</p>
--	--